

H610I-IM-A

HDMI™
HIGH-DEFINITION MULTIMEDIA INTERFACE

Industrial Motherboard

Copyright © 2023 ASUSTeK COMPUTER INC. All Rights Reserved.

No part of this manual, including the products and software described in it, may be reproduced, transmitted, transcribed, stored in a retrieval system, or translated into any language in any form or by any means, except documentation kept by the purchaser for backup purposes, without the express written permission of ASUSTeK COMPUTER INC. ("ASUS").

Product warranty or service will not be extended if: (1) the product is repaired, modified or altered, unless such repair, modification or alteration is authorized in writing by ASUS; or (2) the serial number of the product is defaced or missing.

ASUS PROVIDES THIS MANUAL "AS IS" WITHOUT WARRANTY OF ANY KIND, EITHER EXPRESS OR IMPLIED, INCLUDING BUT NOT LIMITED TO THE IMPLIED WARRANTIES OR CONDITIONS OF MERCHANTABILITY OR FITNESS FOR A PARTICULAR PURPOSE. IN NO EVENT SHALL ASUS, ITS DIRECTORS, OFFICERS, EMPLOYEES OR AGENTS BE LIABLE FOR ANY INDIRECT, SPECIAL, INCIDENTAL, OR CONSEQUENTIAL DAMAGES (INCLUDING DAMAGES FOR LOSS OF PROFITS, LOSS OF BUSINESS, LOSS OF USE OR DATA, INTERRUPTION OF BUSINESS AND THE LIKE), EVEN IF ASUS HAS BEEN ADVISED OF THE POSSIBILITY OF SUCH DAMAGES ARISING FROM ANY DEFECT OR ERROR IN THIS MANUAL OR PRODUCT.

SPECIFICATIONS AND INFORMATION CONTAINED IN THIS MANUAL ARE FURNISHED FOR INFORMATIONAL USE ONLY, AND ARE SUBJECT TO CHANGE AT ANY TIME WITHOUT NOTICE, AND SHOULD NOT BE CONSTRUED AS A COMMITMENT BY ASUS. ASUS ASSUMES NO RESPONSIBILITY OR LIABILITY FOR ANY ERRORS OR INACCURACIES THAT MAY APPEAR IN THIS MANUAL, INCLUDING THE PRODUCTS AND SOFTWARE DESCRIBED IN IT.

Products and corporate names appearing in this manual may or may not be registered trademarks or copyrights of their respective companies, and are used only for identification or explanation and to the owners' benefit, without intent to infringe.

Contents

Chapter 1	Product overview	
1.1	Package contents.....	1-1
1.2	Features	1-1
1.3	Specifications.....	1-2
Chapter 2	Motherboard information	
2.1	Before you proceed	2-1
2.2	Motherboard layout.....	2-2
2.3	Central Processing Unit (CPU)	2-4
2.3.1	Installing the CPU	2-5
2.3.2	CPU heatsink and fan assembly installation.....	2-7
2.4	System memory	2-9
2.5	Jumpers	2-11
2.6	Connectors	2-14
2.6.1	Rear panel connectors.....	2-14
2.6.2	Internal connectors	2-16
Chapter 3	BIOS setup	
3.1	BIOS setup program	3-1
3.1.1	BIOS menu screen.....	3-2
3.2	Main menu	3-2
3.2.1	System Date [Day MM/DD/YYYY]	3-2
3.2.2	System Time [HH:MM:SS].....	3-2
3.3	Advanced menu	3-3
3.3.1	LVDS Configuration	3-3
3.3.2	PCH-FW Configuration	3-4
3.3.3	Trusted Computing	3-4
3.3.4	CPU Configuration	3-4
3.3.5	Graphics Configuration	3-5
3.3.6	Power Management.....	3-6
3.3.7	PCI Express Configuration.....	3-6
3.3.8	Super IO Configuration	3-7
3.3.9	Serial Console Redirection	3-8
3.3.10	SATA Configuration	3-9
3.3.11	Network Stack Configuration	3-10
3.3.12	USB Configuration	3-10

3.3.13	NVMe Configuration.....	3-10
3.3.14	Onboard Devices Configuration.....	3-10
3.3.15	APM Configuration.....	3-11
3.3.16	EZ-Flash	3-12
3.3.17	IO Expander Configuration	3-12
3.3.18	Watchdog Timer.....	3-12
3.4	Hardware Monitor menu	3-12
3.5	Security menu	3-13
3.6	Boot menu	3-14
3.7	Exit menu.....	3-15
Appendix		
	Notices.....	A-1
	Service and Support.....	A-5

Chapter 1

Product overview

1.1 Package contents

Check your industrial motherboard package for the following items.

- 1 x ASUS H610I-IM-A Industrial Motherboard
- 1 x SATA 6.0 Gb/s cable
- 2 x M.2 screw packages
- 1 x ASUS I/O Shield



NOTE: If any of the above items is damaged or missing, contact your distributor or sales representative immediately.

1.2 Features

- LGA1700 socket for Intel® 13th/12th Gen. Core™ i9/ i7/ i5/ i3, Pentium®, and Celeron® Processors
- Two Dual Channel DDR4 3200/2933/2666/2400 MHz Non-ECC SO-DIMMs up to 64GB
- 3 x SATA 6.0 Gb/s, 4 x USB 3.2 Gen 1, 6 COM ports
- 1 x PCIe 4.0 x16 slot, 1 x M.2 Socket 3 with Key M, type 2242/2260/2280 (SATA/PCIe x4 mode), 1 x M.2 Socket 1 with Key E, type 2230 for WIFI/BT device (PCIe & CNVi)
- Multi-display: 2 x HDMI™, 1 x DisplayPort, 1 x LVDS, 1 x Embedded DisplayPort (colay with LVDS, optional)

1.3 Specifications

CPU	LGA1700 socket for Intel® 13 th /12 th Gen. Core™ i9/ i7/ i5/ i3, Pentium®, and Celeron® Processors Supports up to 65W
Chipset	Intel® H610 Chipset
Memory	2 x SO-DIMM, max.64GB, DDR4 3200/2933/2666/2400 MHz SDRAM
Graphics	Integrated graphics processor - Intel® HD Graphics support Multi-output support: HDMI™/DisplayPort/LVDS/eDP ports* <ul style="list-style-type: none"> - Supports HDMI™ output with a maximum resolution of 4096 x 2160 @ 60Hz - Supports DisplayPort output with a maximum resolution of 4096 x 2160 @ 60Hz - Supports LVDS output with a maximum resolution of 1920 x 1200 @ 60Hz - Supports Embedded DisplayPort output with a maximum resolution of 4096 x 2160 @ 60Hz (colay with LVDS, optional) <p>* The system supports up to three displays simultaneously.</p>
Expansion slots	1 x PCIe 4.0 x16 slot 1 x M.2 Socket 3 with key M, type 2242/2260/2280 (SATA/PCIe x4 mode) 1 x M.2 Socket 1 with Key E, type 2230 for WIFI/BT device (PCIe & CNVi)
Storage	3 x SATA Gen 3.0, up to 6.0 Gb/s ports 1 x M.2 Socket 3 with key M, type 2242/2260/2280 (SATA/PCIe x4 mode)
LAN	2 x LAN (RJ45) ports: 1 x Intel® i219V 1 x Intel® i210AT
Audio	Realtek ALC 897 High Definition Audio Line-Out, Mic in
Rear I/O ports	1 x HDMI™ port 1 x DisplayPort 4 x USB 3.2 Gen 1 ports 2 x LAN (RJ45) ports 2 x COM ports (RS232/422/485) 2 x Audio jacks
Internal I/O connectors	4 x COM headers (RS232) 2 x USB 2.0 header supports 4 additional USB 2.0 ports

(continued on the next page)

Internal I/O connectors	1 x CPU Fan header (PWM mode) 1 x Chassis Fan header (PWM mode) 1 x Chassis Intrusion header 1 x Front Panel Audio header (AAFP) 1 x System Panel header 1 x Clear CMOS header 1 x Speaker header 1 x COM Debug header 1 x GPIO header (8-bit) 1 x AT/ATX mode selection jumper 1 x 24-pin ATX power connector 2 x 4-pin ATX power connectors 1 x SPI TPM header 1 x LCD Panel monitor switch header
Watch dog timer	Yes
Power requirement	AT/ATX mode
Operation Temperature	0~60°C
Non-Operation Temperature	-40~85°C
Relative Humidity	10%~95% (non-coagulation)
OS support	Windows® 10 (64-bit) Windows® 10 IoT Enterprise Ubuntu RedHat Enterprise Fedora Workstation OpenSUSE
Certification	CE, FCC
Form Factor	ATX Form Factor, 12"x 13" (24.4cm x 30.5cm)



NOTE: Specifications are subject to change without notice.

Chapter 2

Motherboard information

2.1 Before you proceed

Take note of the following precautions before you install motherboard components or change any motherboard settings.



CAUTION!

- Unplug the power cord from the wall socket before touching any component.
 - Before handling components, use a grounded wrist strap or touch a safely grounded object or a metal object, such as the power supply case, to avoid damaging them due to static electricity.
 - Hold components by the edges to avoid touching the ICs on them.
 - Whenever you uninstall any component, place it on a grounded antistatic pad or in the bag that came with the component.
 - Before you install or remove any component, always remove the AC power by unplugging the power cord from the power outlet. Failure to do so may cause severe damage to the motherboard, peripherals, or components.
-

2.2 Motherboard layout



NOTE: Place nine screws into the holes indicated by circles to secure the motherboard to the chassis.



CAUTION! Do not overtighten the screws! Doing so can damage the motherboard.

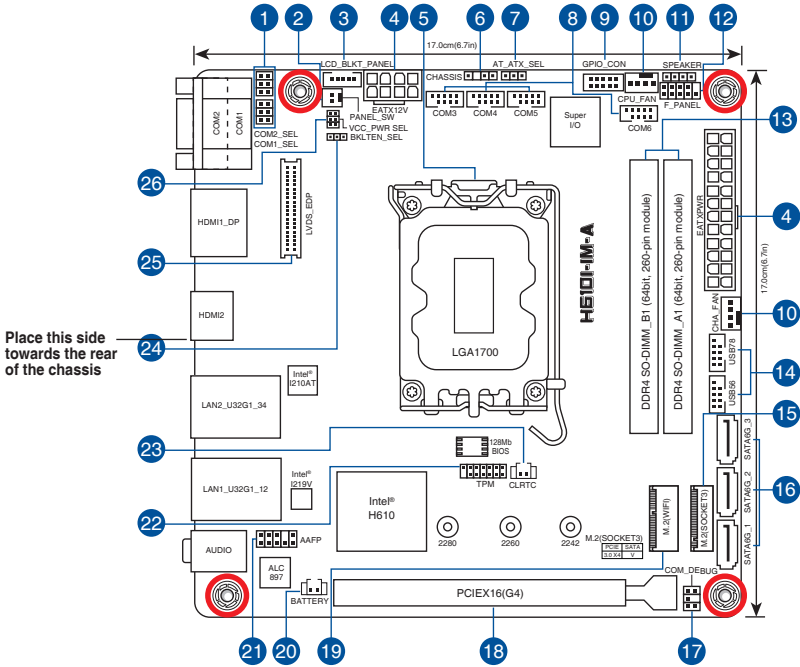

Connectors/Jumpers/Slots		Page
1.	COM RING/+5V/+12V selection jumper (COM1/2_SEL)	2-12
2.	LCD Panel monitor switch header (2-pin PANEL_SW)	2-24
3.	LVDS Backlight Panel header (5-pin LCD_BLK_PANEL)	2-25
4.	ATX Power connector (24-pin ATXPWR, 2 x 4-pin EATX12V)	2-16
5.	Intel® LGA1700 CPU socket	2-4
6.	Chassis Intrusion header (4-1 pin CHASSIS)	2-20
7.	AT/ATX mode selection jumper (3-pin AT_ATX_SEL)	2-12
8.	COM Port headers (10-1 pin COM3 - COM6)	2-22
9.	General Purpose Input/Output header (GPIO_CON)	2-21
10.	CPU and Chassis Fan headers (4-pin CPU_FAN, 4-pin CHA_FAN)	2-16
11.	Speaker header (4-pin SPEAKER)	2-20
12.	System Panel header (10-1 pin F_PANEL)	2-19
13.	DDR4 SO-DIMM slots	2-9
14.	USB 2.0 headers (10-1 pin USB56, USB78)	2-17
15.	M.2 slot (SOCKET 3)	2-18
16.	SATA 6.0 Gb/s ports (7-pin SATA6G_1-3)	2-21
17.	COM Debug header (5-1 pin COM_DEBUG)	2-24
18.	PCIe 4.0 x16 slot	2-26
19.	M.2 Wi-Fi slot	2-18
20.	RTC Battery header (2-pin BATTERY)	2-22
21.	Front Panel Audio header (10-1 pin AAFP)	2-23
22.	TPM header (14-1 pin TPM)	2-17
23.	Clear RTC RAM (2-pin CLRRTC)	2-11
24.	LVDS Panel Backlight Enable Signal Selection jumper (BKLTEN_SEL)	2-13
25.	LVDS/EDP header (40-pin LVDS_EDP)	2-25
26.	LVDS Panel VCC Power Selection jumper (6-pin VCC_PWR_SEL)	2-13

2.3 Central Processing Unit (CPU)

The motherboard comes with a surface mount LGA1700 socket designed for the Intel® 13th/12th Gen. Core™ i9 / Core™ i7 / Core™ i5 / Core™ i3, Pentium®, and Celeron® Processors.

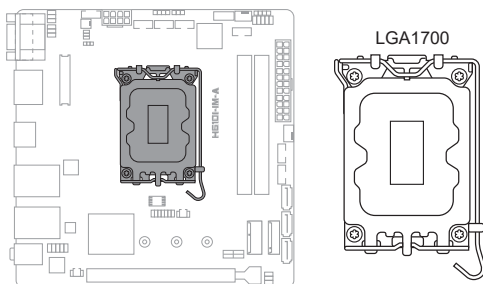

IMPORTANT: Unplug all power cables before installing the CPU.



CAUTION!

- Ensure that you install the correct CPU designed for LGA1700 socket only. DO NOT install a CPU designed for other sockets on the LGA1700 socket
 - Upon purchase of the motherboard, ensure that the PnP cap is on the socket and the socket contacts are not bent. Contact your retailer immediately if the PnP cap is missing, or if you see any damage to the PnP cap/socket contacts/motherboard components. ASUS will shoulder the cost of repair only if the damage is shipment/transit-related.
 - Keep the cap after installing the motherboard. ASUS will process Return Merchandise Authorization (RMA) requests only if the motherboard comes with the cap on the LGA1700 socket.
 - The product warranty does not cover damage to the socket contacts resulting from incorrect CPU installation/removal, or misplacement/loss/incorrect removal of the PnP cap.
-

2.3.1 Installing the CPU



- Ensure that you install the correct CPU designed for LGA1700 socket only. **DO NOT** install a CPU designed for LGA1155, LGA1156, LGA1151, and LGA1200 sockets on the LGA1700 socket.
- ASUS will not cover damages resulting from incorrect CPU installation/removal, incorrect CPU orientation/placement, or other damages resulting from negligence by the user.

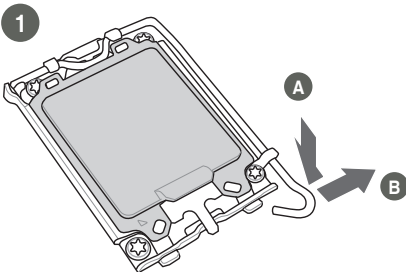
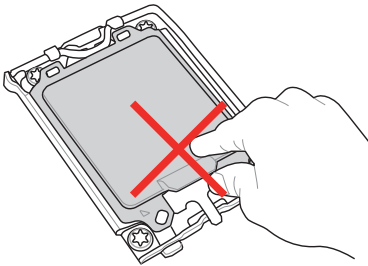

Take caution when lifting the load lever, ensure to hold onto the load lever when releasing the load lever. Letting go of the load lever immediately after releasing it may cause the load lever to spring back and cause damage to your motherboard.

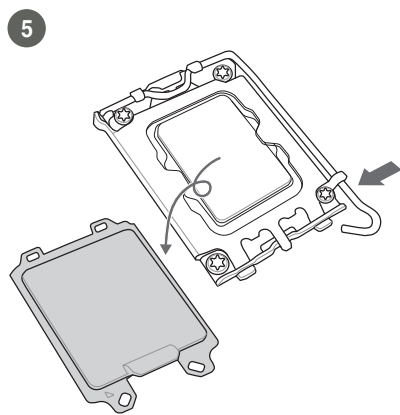
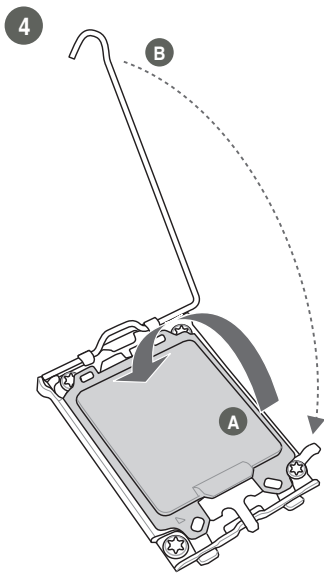
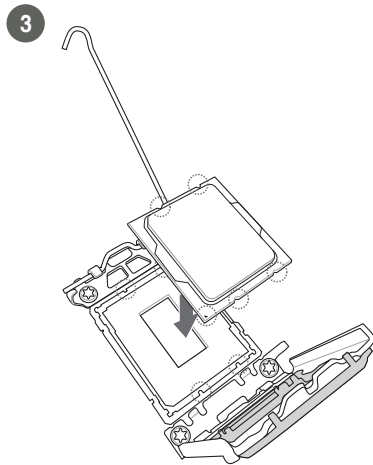
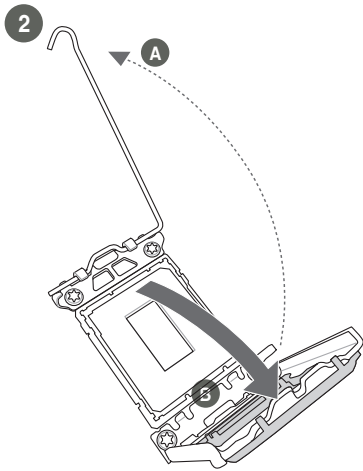

2.3.2 CPU heatsink and fan assembly installation

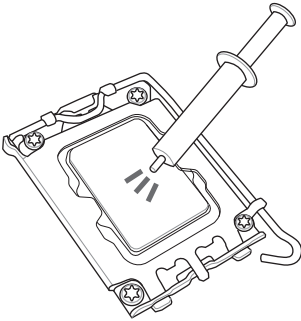

CAUTION! Apply the Thermal Interface Material to the CPU heatsink and CPU before you install the heatsink and fan if necessary.

To install the CPU heatsink and fan assembly

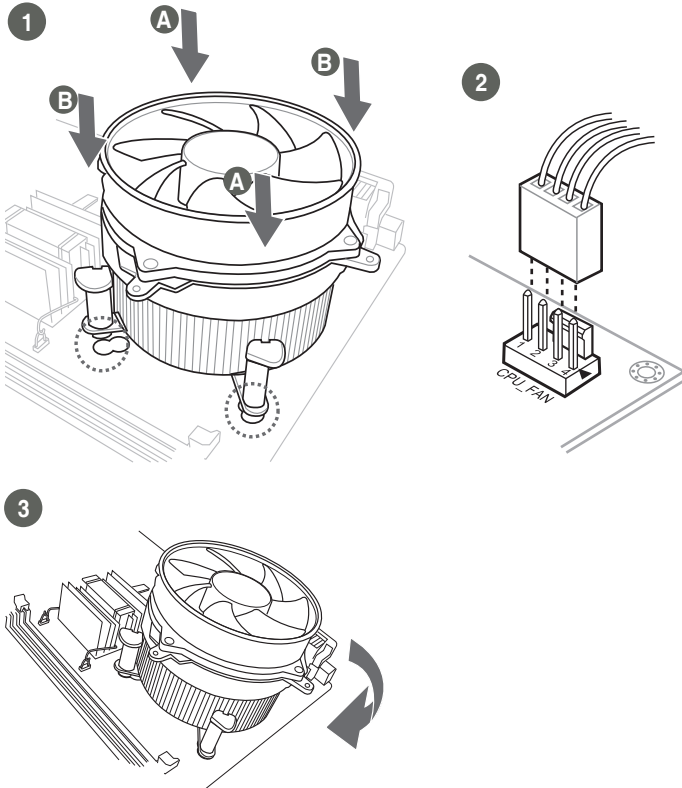

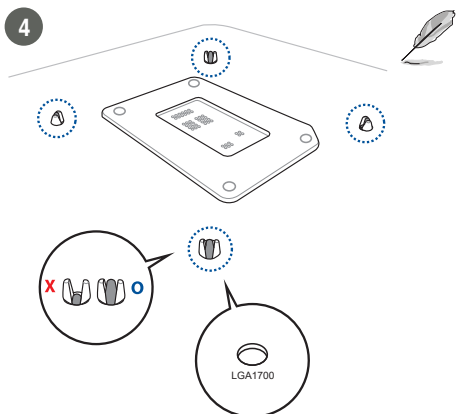

- We recommend using a LGA1700 compatible cooling system on an Intel® 600 series motherboard.
- Push-pin type LGA1200 compatible cooling systems cannot be installed to this motherboard.

To uninstall the CPU heatsink and fan assembly

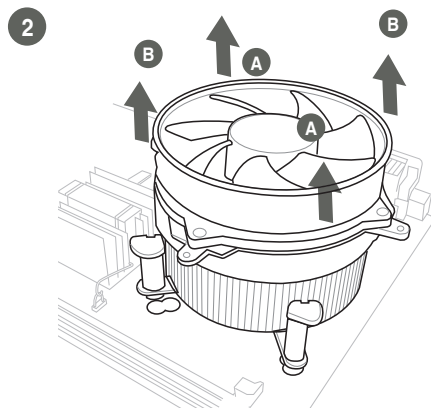
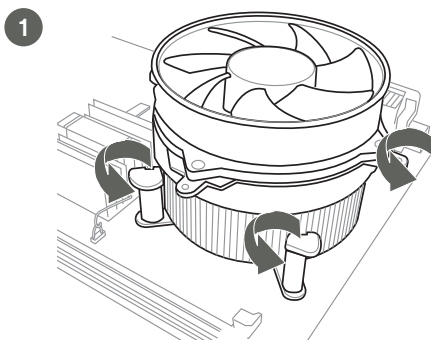

2.4 System memory

This motherboard comes with two Double Data Rate 4 (DDR4) Dual Inline Memory Module (DIMM) sockets. The figure below illustrates the location of the DDR4 DIMM sockets:

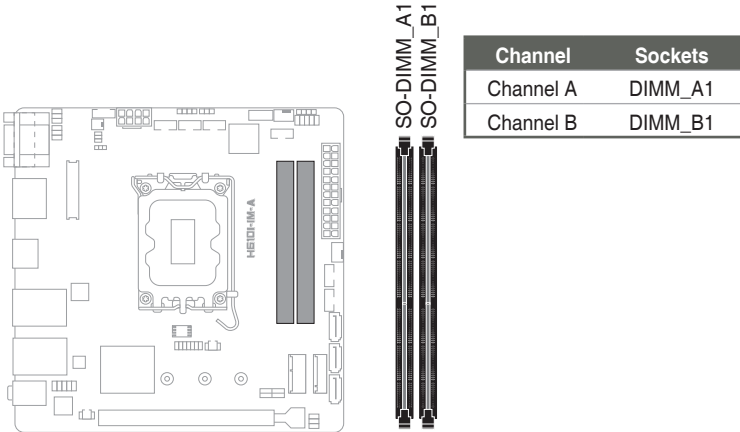

IMPORTANT!

- You may install varying memory sizes in Channel A and Channel B. The system maps the total size of the lower-sized channel for the dual-channel configuration. Any excess memory from the higher-sized channel is then mapped for single-channel operation.
- Always install the DIMMs with the same CAS Latency. For an optimum compatibility, we recommend that you install memory modules of the same version or data code (D/C) from the same vendor. Check with the vendor to get the correct memory modules.
- According to Intel® CPU spec, DIMM voltage below 1.35V is recommended to protect the CPU.



NOTE: Visit the ASUS website at www.asus.com for the latest QVL.

Recommended memory configuration

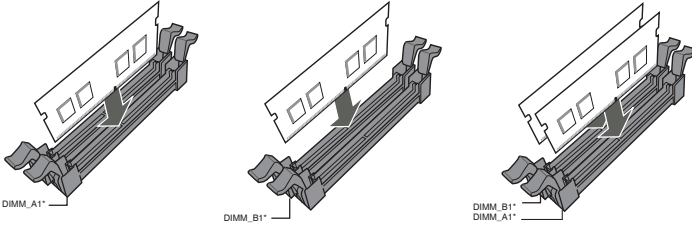

Installing a DIMM

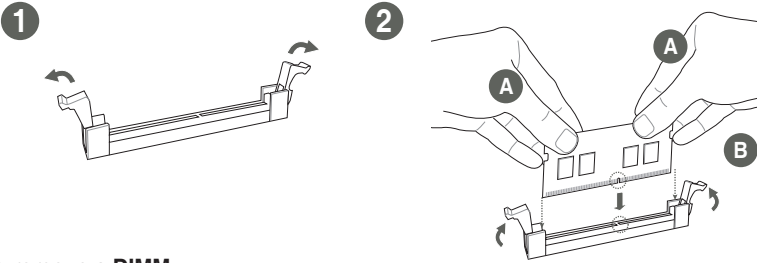

To remove a DIMM

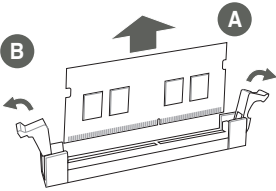

2.5 Jumpers

1. Clear RTC RAM (2-pin CLRRTC)

This header allows you to clear the CMOS RTC RAM data of the system setup information such as date, time, and system passwords.

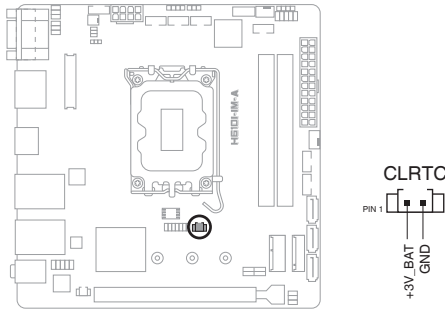

Connector type	HEADER 1x2p, 2.54mm pitch, S/T
-----------------------	--------------------------------

To erase the RTC RAM:

1. Turn OFF the computer and unplug the power cord.
2. Use a metal object such as a screwdriver to short the two pins.
3. Plug the power cord and turn ON the computer.
4. Hold down the key during the boot process and enter BIOS setup to re-enter data.



NOTE: If the steps above do not help, remove the onboard battery and move the jumper again to clear the CMOS RTC RAM data. After clearing the CMOS, reinstall the battery.

2. COM Ring/+5V/+12V selection jumper (6-pin COM1/2_SEL)

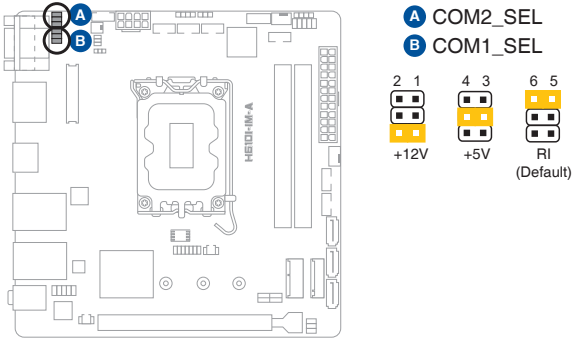

Setting	Pins
+12V	1-2
+5V	3-4
Ring (Default)	5-6

3. AT/ATX mode selection jumper (3-pin AT_ATX_SEL)

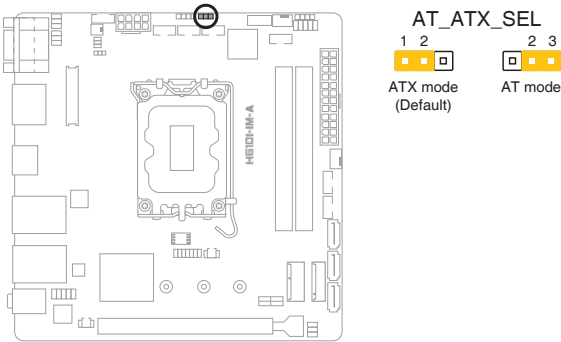

Pins	
1-2 (Default)	ATX mode
2-3	AT mode

Connector type HEADER 1x3p, 2.54mm pitch, S/T

4. LVDS Panel Backlight Enable Signal Selection jumper (BKLTEN_SEL)

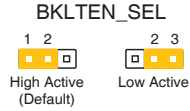
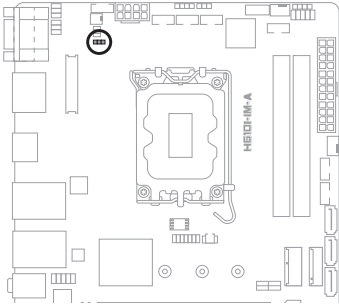

BKLTEN_SEL	Pins
HIGH active	1-2
LOW active	2-3

Connector type HEADER 1x3p, 2.54mm pitch, S/T

5. LVDS Panel VCC Power Selection jumper (6-pin VCC_PWR_SEL)

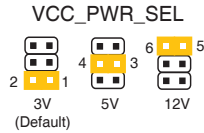
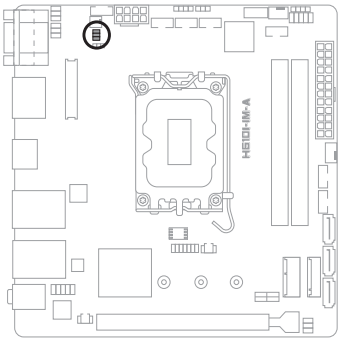

Setting	Pins
12V	5-6
5V	4-3
3V (Default)	1-2

Connector type HEADER 1 x 3p, 2.54mm pitch, S/T

2.6 Connectors

2.6.1 Rear panel connectors

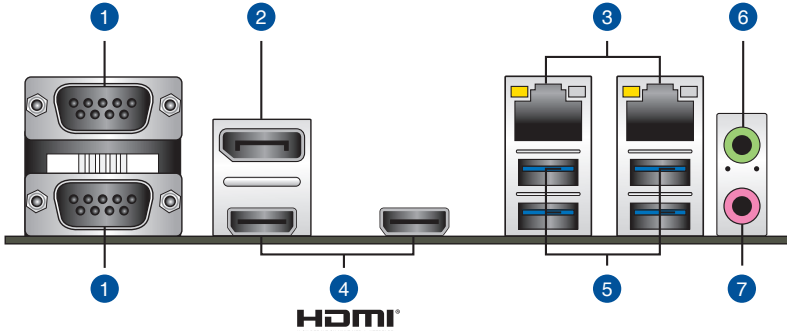

1. **COM ports (COM, RS232/RS422/RS485).** These ports connect modems, or other devices that conform with serial specification.
2. **DisplayPort.** This port is for a DisplayPort-compatible device.
3. **LAN (RJ-45) ports.** These ports allow Gigabit connection to a Local Area Network (LAN) through a network hub.

LAN port LED indications

Activity/Link LED		Speed LED	
Status	Description	Status	Description
Off	No link	OFF	10Mbps connection
Orange	Linked	ORANGE	100Mbps connection
Orange (Blinking)	Data activity	GREEN	1Gbps connection
Orange (Blinking then steady)	Ready to wake up from S5 mode		

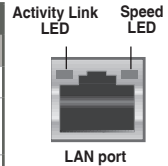

4. **HDMI™ ports.** These ports are for High-Definition Multimedia Interface (HDMI™) connectors, and are HDCP compliant allowing playback of HD DVD, Blu-ray, and other protected content.
5. **USB 3.2 Gen 1 (up to 5Gbps) ports.** These 9-pin Universal Serial Bus (USB) ports are for USB 3.2 Gen 1 devices.
6. **Line Out port (lime).** This port connects to a headphone or a speaker. In the 4.1, and 5.1 channel configurations, the function of this port becomes Front Speaker Out.
7. **Microphone port (pink).** This port connects to a microphone.



Refer to the audio configuration table for the function of the audio ports in 2, 4, 5.1, or 7.1-channel configuration.

Audio 2, 4, 5.1 or 7.1-channel configuration

Port	Headset 2-channel	4-channel	5.1-channel	7.1-channel
Lime (Rear panel)	Line Out	Front Speaker Out	Front Speaker Out	Front Speaker Out
Pink (Rear panel)	Mic In	Mic In	Bass/Center	Bass/Center
Lime (Front panel)	-	-	-	Side Speaker Out



To configure a 7.1-channel audio output:

Use a chassis with HD audio module in the front panel to support a 7.1-channel audio output.

2.6.2 Internal connectors

1. ATX Power connectors (24-pin ATXPWR, 2 x 4-pin EATX12V)

Correctly orient the ATX power supply plugs into these connectors and push down firmly until the connectors completely fit.

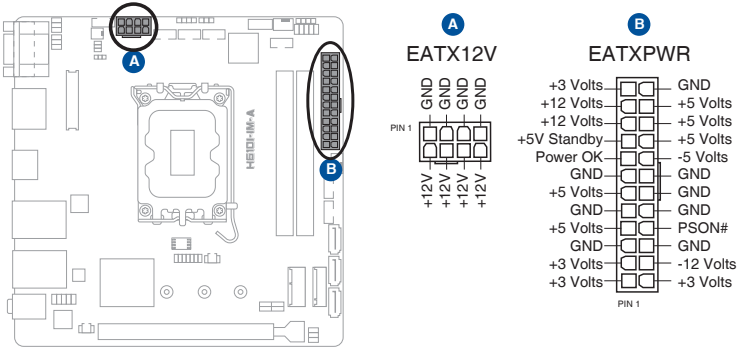

Connector type	POWER CON 24P S/T
	POWER CON 8P S/T

2. CPU and Chassis Fan headers (4-pin CPU_FAN, 4-pin CHA_FAN)

Connect the fan cables to the fan headers on the motherboard, ensuring that the black wire of each cable matches the ground pin of the header.

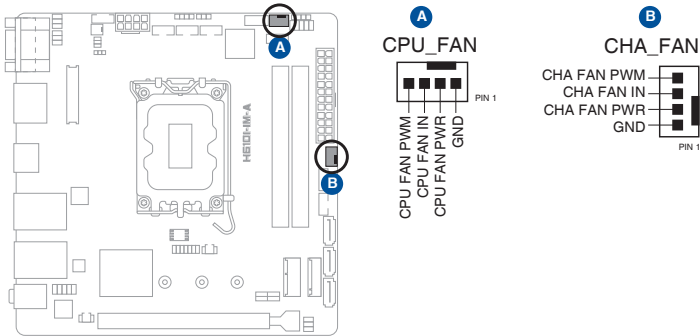

Connector type	WAFER HD 4p, 2.54mm pitch, S/T
-----------------------	--------------------------------



CAUTION: Do not forget to connect the fan cables to the fan headers. Insufficient air flow inside the system may damage the motherboard components. These are not jumpers! Do not place jumper caps on the fan headers!

3. USB 2.0 headers (10-1 pin USB56, USB78)

These headers are for USB 2.0 ports. Connect a USB cable to the header. The USB headers comply with USB 2.0 specification that supports up to 480 Mbps connection speed.

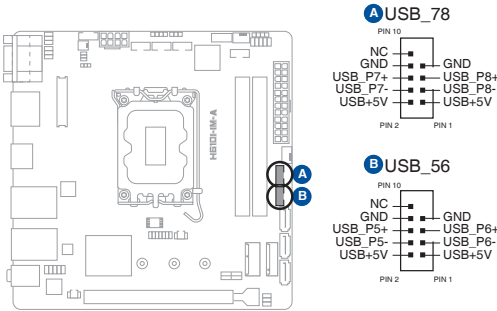

Connector type HEADER 2x5p, K9, 2mm pitch



CAUTION! Never connect a 1394 cable to the USB connector. Doing so will damage the motherboard.



NOTE: The USB cable is purchased separately.

4. TPM header (14-1 pin TPM)

This header supports a Trusted Platform Module (TPM) system with a Serial Peripheral Interface (SPI), allowing you to securely store keys, digital certificates, passwords and data. A TPM system also enhances network security, protects digital identities, and ensures platform integrity.

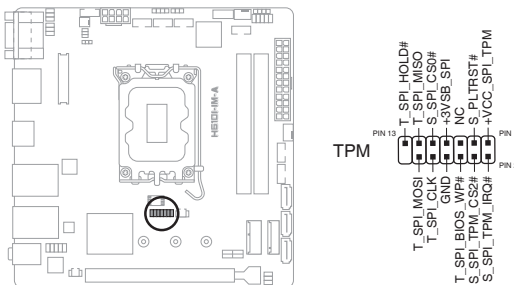

Connector type HEADER 2x7p, K14, 2.0mm pitch

5. M.2 slot (SOCKET 3)

This slot allows you to install an M.2 SSD module.

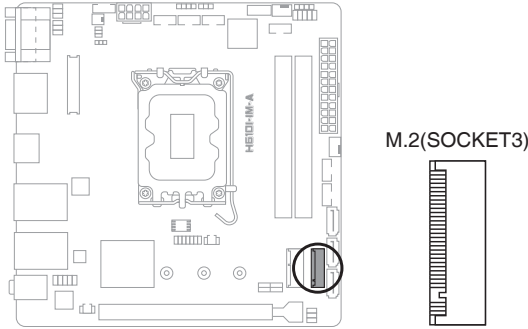

Connector type NGFF KEY-M 67P, 8.5H

NOTES:



- The M.2 SSD module is purchased separately.
- This slot supports M Key and 2242/2260/2280 storage devices.

6. M.2 Wi-Fi slot

This slot connects to an M.2 Wi-Fi device.

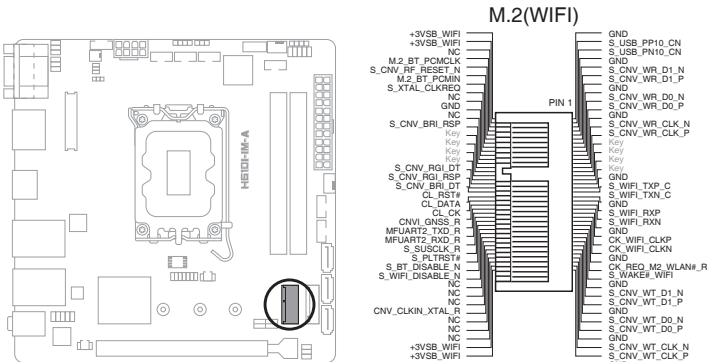

NOTE: The M.2 Wi-Fi module is purchased separately.

7. System Panel header (10-1 pin F_PANEL)

This header supports several chassis-mounted functions.

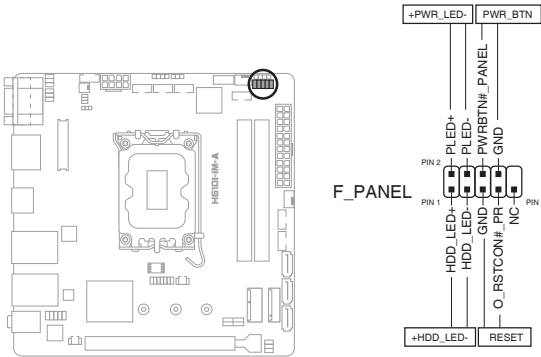

Connector type HEADER 2x5p, K10, 2.54mm pitch

- **System power LED (2-pin +PWR_LED)**

This 2-pin header is for the system power LED. Connect the chassis power LED cable to this header. The system power LED lights up when you turn on the system power, and blinks when the system is in sleep mode.

- **Hard disk drive activity LED (2-pin +HDD_LED)**

This 2-pin header is for the HDD Activity LED. Connect the HDD Activity LED cable to this header. The IDE LED lights up or flashes when data is read from or written to the HDD.

- **ATX power button/soft-off button (2-pin PWR_BTN)**

This 2-pin header is for the system power button.

- **Reset button (2-pin RESET)**

This 2-pin header is for the chassis-mounted reset button for system reboot without turning off the system power.

8. Speaker header (4-pin SPEAKER)

The 4-pin header is for the chassis-mounted system warning speaker. The speaker allows you to hear system beeps and warnings.

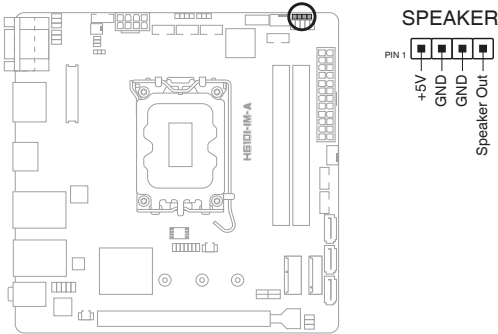

Connector type HEADER 1x4p, 2.54mm pitch, S/T

9. Chassis Intrusion header (4-1 pin_CHASSIS)

This header is for a chassis-mounted intrusion detection sensor or switch. Connect one end of the chassis intrusion sensor or switch cable to this connector. The chassis intrusion sensor or switch sends a low-level signal to this connector when a chassis component is installed. The signal is then generated as a chassis intrusion event.

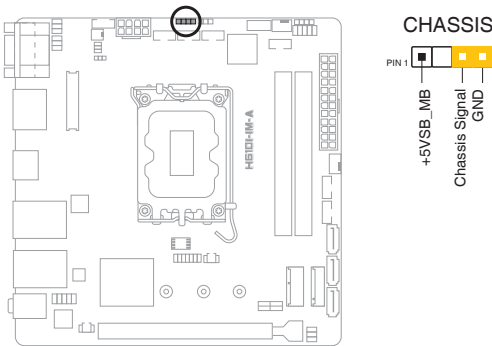

Connector type HEADER 4p, K2, 2.54mm pitch

10. SATA 6.0Gb/s ports (7-pin SATA6G_1-4)

These ports connect to SATA 6.0 Gb/s hard disk drives or an optical drive via SATA 6.0 Gb/s signal cables.

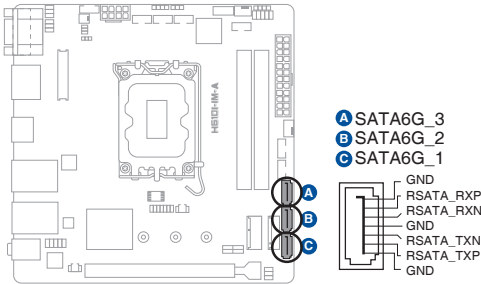

Connector type SATA CON 7P S/T

11. General Purpose Input/Output header (GPIO_CON)

This header is for a general purpose input/output module which allows you to customize the digital signal input/output.

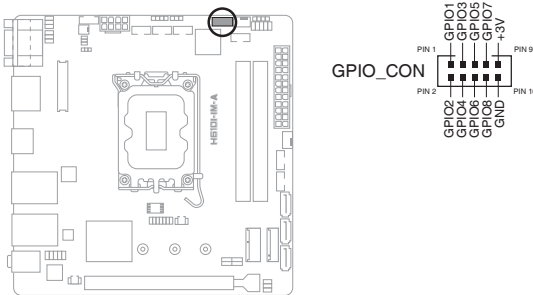

Connector type WAFER HD 2x5p, 2.0mm pitch, S/T

12. COM Port headers (10-pin COM3 - COM6)

These headers are for serial (COM) ports. Connect the serial port cables to these headers, then install the module to a slot opening at the back of the system chassis.

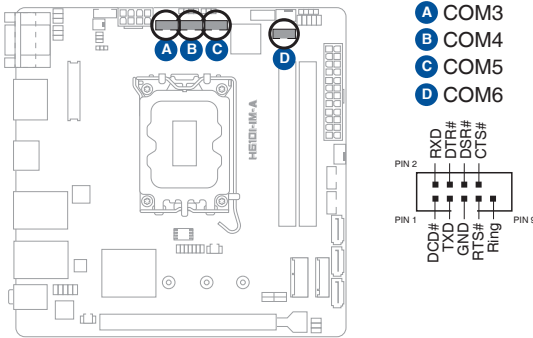

Connector type HEADER 2x5p, K10, 2.00mm pitch



NOTE: The serial port cable is purchased separately.

13. RTC Battery header (2-pin BATTERY)

This header is for the lithium CMOS battery.

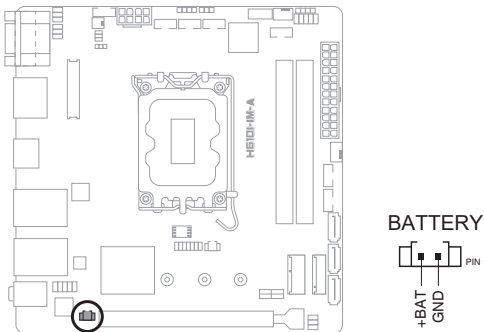

14. Front Panel Audio header (10-1 pin AAFP)

This header is for a chassis-mounted front panel audio I/O module that supports HD Audio standard. Connect one end of the front panel audio I/O module cable to this header.

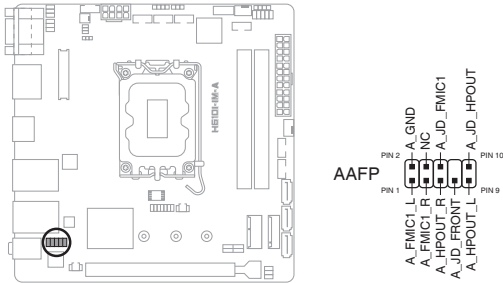

Connector type HEADER 2x5p, K8, 2.54mm pitch



IMPORTANT!

- We recommend that you connect a high-definition front panel audio module to this header to avail of the motherboard's high-definition audio capability.
- If you want to connect a high-definition front panel audio module to this header, set the **HD Audio Controller** item in the BIOS setup to **[Enabled]**.

15. COM Debug header (5-1 pin COM_DEBUG)

This header allows connection to a COM Debug card.

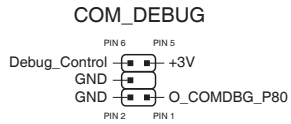
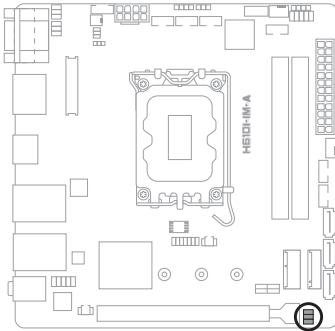

Connector type HEADER 2x3p, K3, 2.54 mm pitch, S/T



NOTE: The COM Debug Card is purchased separately.

16. LCD Panel monitor switch header (2-pin PANEL_SW)

This 2-pin header is for connecting a monitor switch that can turn on/off the LCD panel display backlight.

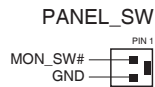
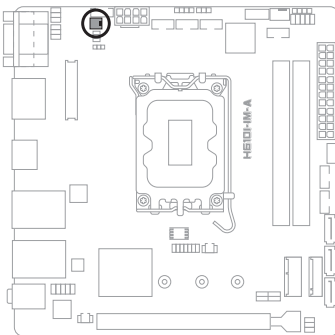

17. LVDS Backlight Panel header (5-pin LCD_BLKT_PANEL)

This header is for the LCD panel brightness controls.

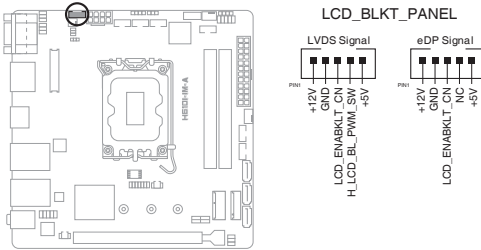

Connector type

WAFER 6p, 2.0mm pitch

18. LVDS/EDP header (40-pin LVDS_EDP)

This header is for an internal LVDS or embedded DisplayPort connection.

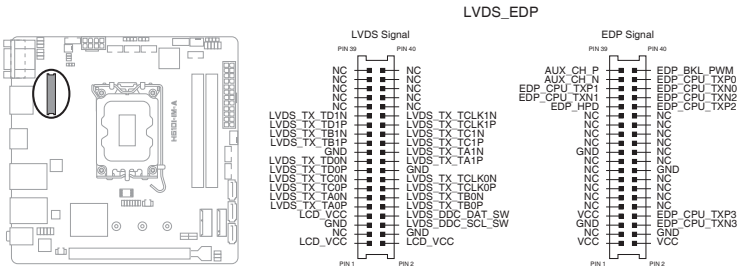

19. PCIe 4.0 x16 slot (PCIEX16(G4))

This slot supports a PCIe 4.0 x16 graphics card that complies with the PCI Express specification.

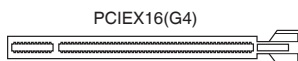
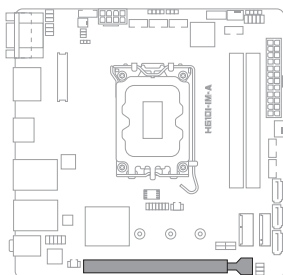

Chapter 3

BIOS setup



Scan the QR code to view the BIOS update guide.



3.1 BIOS setup program

Use the BIOS Setup program to update the BIOS or configure its parameters. The BIOS screens include navigation keys and brief online help to guide you in using the BIOS Setup program.

Entering BIOS Setup at startup

To enter BIOS Setup at startup:

Press <Esc> or during the Power-On Self Test (POST). If you do not press <Esc> or , POST continues with its routines.

Entering BIOS Setup after POST

To enter BIOS Setup after POST:

- Press <Ctrl>+<Alt>+ simultaneously.
- Press the reset button on the system chassis.
- Press the power button to turn the system off then back on. Do this option only if you failed to enter BIOS Setup using the first two options.



NOTE: Using the power button, reset button, or the <Ctrl>+<Alt>+ keys to reboot a running operating system can cause damage to your data or system. Always shut down the system properly from the operating system.



IMPORTANT:

- Visit the ASUS website at www.asus.com to download the latest BIOS file for this motherboard.
- The default BIOS settings for this motherboard apply to most working conditions and ensures optimal performance. If the system becomes unstable after changing any BIOS settings, load the default settings to regain system stability. Select the option **Restore Defaults** under the Exit Menu or press hotkey F3.
- The BIOS setup screens shown in this section are for reference purposes only, and may not exactly match what you see on your screen.

3.1.1 BIOS menu screen

Menu bar

The menu bar on top of the screen has the following main items:

Main	For changing the basic system configuration
Advanced	For changing the advanced system settings
Hardware Monitor	For displaying the system temperature and changing the fan settings
Security	For configuring the system security settings
Boot	For changing the system boot configuration.
Exit	For selecting the save options and default options.

To select an item on the menu bar, press the right or left arrow key on the keyboard until the desired item is highlighted.

3.2 Main menu

The Main menu provides you an overview of the basic system information, and allows you to set the system date, time, language, and security settings.

3.2.1 System Date [Day MM/DD/YYYY]

Allows you to set the system date.

3.2.2 System Time [HH:MM:SS]

Allows you to set the system time.

3.3 Advanced menu

The Advanced menu items allow you to change the settings for the CPU and other system devices.



Be cautious when changing the settings of the Advanced menu items. Incorrect field values can cause the system to malfunction.

3.3.1 LVDS Configuration

The items in this menu show the LVDS-related information that the BIOS automatically detects.



The following items appear only when you set **LVDS** to **[Enabled]**.

All-in-One Chassis

Allows you to select All-in-One (AiO) chassis (if applicable) for simplified AiO configuration. Configuration options: [None] [1920*1080 LVDS1] [1920*1080 LVDS2] [1920*1080 LVDS3] [1600*900 LVDS4]



Improper selection of AiO chassis may result in incorrect operation or potential damage to AiO chassis hardware.

EDID Data Source

Allows you to select the EDID data source. Configuration options: [Pre-defined] [Flat Panel Display]



The following items appear only when you set the previous item to [Pre-defined].

Pre-defined LVDS Panel Type

Allow you to select the LVDS panel used by the internal graphics device by selecting the appropriate setup item. Configuration options: [VBIOS Default] [640x480] [800x600] [1024x768] [1280x1024] [1400x1050(RB) LVDS1] [1400x1050 LVDS2] [1600x1200 LVDS] [1366x768 LVDS] [1680x1050] [1920X1200] [1440x900 ;VDS] [1600X900 LVDS] [1024X768 LVDS2] [1280X800] [1920X1080 LVDS] [2048X1536 LVDS]

Inverter Polarity

Allows you to select the inverter board polarity. Configuration options: [Inverted] [Normal]

Channel Select

Allows you to select the channel. Configuration options: [Dual Channel] [Single Channel]

Mode Select

Allows you to select the mode. Configuration options: [JEIDA] [VESA 6bit] [VESA 8bit] [VESA 10bit]

3.3.2 PCH-FW Configuration

TPM Device Selection

This item allows you to select the TPM device. Configuration options: [dTPM] [PTT]

3.3.3 Trusted Computing

Security Device Support

This item allows you to enable or disable BIOS support for security devices. Configuration options: [Disable] [Enable]

3.3.4 CPU Configuration

The items in this menu show CPU-related information the BIOS automatically detects.



The items shown in the submenu may be different depending on the type of CPU installed.

Intel (VMX) Virtualization Technology

When set to **[Enabled]**, a VMM can utilize the additional hardware capabilities provided by Vanderpool Technology. Configuration options: [Disabled] [Enabled]

Hyper-Threading

The Intel Hyper-Threading Technology allows a hyper-threading processor to appear as two logical processors to the operating system, allowing the operating system to schedule two threads or processes simultaneously.

[Enabled] Two threads per activated core are enabled.

[Disabled] Only one thread per activated core is enabled.

Intel Trusted Execution Technology

When set to **[Enabled]**, allows you to enable the utilization of additional hardware capabilities provided by Intel® Trusted Execution Technology and requires a full power cycle. Configuration options: [Disabled] [Enabled]

VT-d [Disabled]

Allows you to enable or disable VT-d function on MCH. Configuration options: [Disabled] [Enabled]

CPU - Power Management Control

This item allows you to manage and configure the CPU's power.

Intel(R) SpeedStep(tm)

This item allows your system to support more than two frequency ranges.
Configuration options: [Disabled] [Enabled]

Intel(R) Speed Shift Technology

This item allows you to enable or disable Intel(R) Speed Shift Technology support. When enabled, CPPC v2 interface allows hardware controlled P-state. Configuration options: [Disabled] [Enabled]

Turbo Mode

This item allows you to enable or disable Turbo Mode for your processor.
Configuration options: [Enabled] [Disabled]

CPU C states

[Enabled] Enables the CPU C states.

[Disabled] Disables the CPU C states.

Enhanced C-states

[Disabled] Disables enhanced C1 state.

[Enabled] Enables enhanced C1 state.

Power Limit 1 Override

[Disabled] Disables power limit 1.

[Enabled] Enables power limit 1.

Power Limit 2 Override

[Disabled] Disables power limit 2.

[Enabled] Enables power limit 2.

Power Limit 2

This item allows you to input the value of power limit 2 in milliwatts. If the value is 0, BIOS will program this value as 1.25 times of Processor Base Power (TDP). For 12.50W, enter 12500. Processor applies control policies so that the package power does not exceed this limit.

3.3.5 Graphics Configuration

Allows you to select a primary display from IGFX, PEG and PCI graphical devices.

Primary Display

Allows you to select which of the IGFX/PEG/PCI Graphics device should be the Primary Display. Configuration options: [Auto] [IGFX] [PEG Slot] [PCH PCI]

Internal Graphics

[Auto] Keep IGFX enabled base on the setup options.

[Disabled] Disables internal graphics.

[Enabled] Enables internal graphics.

RC6 (Render Standby)

Allows you to enable or disable render standby support. Configuration options: [Disabled] [Enabled]

3.3.6 Power Management

Enable ACPI Auto Configuration

Allow you to enable/disable the ACPI Auto configuration. Configuration options: [Disabled] [Enabled]

Enable Hibernation

Allow you to enable or disable S4 hibernation. Configuration options: [Disabled] [Enabled]

ACPI Sleep State

Allow you to select the ACPI sleep state. Configuration options: [Suspend Disabled] [S3 (Suspend to RAM)]

3.3.7 PCI Express Configuration

Allows you to select a PEG or PCI graphical device.

PCIEX16 Slot

PCI Express Root Port 2

This item allows you to control the PCI Express Root Port. Configuration options: [Disabled] [Enabled]

PCIe Speed

Configures the speed of PCIEX16 (G4) slot. Configuration options: [Auto] [Gen1] [Gen2] [Gen3] [Gen4]

Detect Timeout

Allows you to set the time (milliseconds) of waiting for link to exit Detect state for enabled ports before assuming there is no device and potentially disabling the port. Use the <+> and <-> keys to adjust the value or input the desired value.

Detect Non-Compliance Device

Allows you to enable or disable the detection function of non-compliance PCI Express device. Configuration options: [Disabled] [Enabled]

3.3.8 Super IO Configuration

NCT6126D Super IO Configuration

Serial Port 1 Configuration

Serial Port

Allows you to enable or disable the serial port (COM). Configuration options: [Disabled] [Enabled]



The following items appear only when you set **Serial Port** to **[Enabled]**.

COM1 Control

Allows you to select the COM1 mode. Configuration options: [RS232] [RS422] [RS485]

Serial Port 2 Configuration

Serial Port

Allows you to enable or disable the serial port (COM). Configuration options: [Disabled] [Enabled]



The following item appears only when you set **Serial Port** to **[Enabled]**.

COM2 Control

Allows you to select the COM2 mode. Configuration options: [RS232] [RS422] [RS485]

Serial Port 3 Configuration

Serial Port

Allows you to enable or disable the serial port (COM). Configuration options: [Disabled] [Enabled]

Serial Port 4 Configuration

Serial Port

Allows you to enable or disable the serial port (COM). Configuration options: [Disabled] [Enabled]

Serial Port 5 Configuration

Serial Port

Allows you to enable or disable the serial port (COM). Configuration options: [Disabled] [Enabled]

Serial Port 6 Configuration

Serial Port

Allows you to enable or disable the serial port (COM). Configuration options: [Disabled] [Enabled]

3.3.9 Serial Console Redirection

COM1~COM6

Console Redirection

Allows you enable or disable the console redirection feature. Configuration options: [Enabled] [Disabled]

Console Redirection Settings

The settings specify how the host computer and the remote computer (which the user is using) will exchange data. Both computers should have the same or compatible settings.

Terminal Type

Configuration options: [VT100] [VT100Plus] [VT-UTF8] [ANSI]

[VT100] ASCII char set.

[VT100Plus] Extends VT100 to support color, function keys, etc.

[VT-UTF8] Uses UTF8 encoding to map Unicode chars onto 1 or more bytes.

[ANSI] Extended ASCII char set.

Bits per second

Allows you to select serial port transmission speed. The speed must be matched on the other side. Long or noisy lines may require lower speeds.

Configuration options: [9600] [19200] [38400] [57600] [115200]

Data Bits

Configuration options: [7] [8]

Parity

A parity bit can be sent with the data bits to detect some transmission errors.

Configuration options: [None] [Even] [Odd] [Mark] [Space]

[None] Disables parity check.

[Even] Parity bit is 0 if the num of 1's in the data bits is even.

[Odd] Parity bit is 0 if the num of 1's in the data bits is odd.

[Mark] Parity bit is always 1.

[Space] Parity bit is always 0.



Mark and Space Parity do not allow for error detection.

Stop Bits

Stop bits indicate the end of a serial data packet. The standard setting is 1 stop bit. Communication with slow devices may require more than 1 stop bit.

Configuration options: [1] [2]

Flow Control

Flow control can prevent data loss from buffer overflow. When sending data, if the receiving buffers are full, a "stop" signal can be sent to stop the

data flow. Once the buffers are empty, a “start” signal can be sent to re-start the flow. Hardware flow control uses two wires to send start/stop signals. Configuration options: [None] [Hardware RTS/CTS]

VT-UTF8 Combo Key Support

Allows you to enable or disable VT-UTF8 Combination Key Support for ANSI/VT100 terminals. Configuration options: [Disabled] [Enabled]

Recorder Mode

With this mode enabled only text will be sent. This is to capture Terminal data. Configuration options: [Disabled] [Enabled]

Resolution 100x31

Allows you to enable or disable extended terminal resolution. Configuration options: [Disabled] [Enabled]

Putty KeyPad

Allows you to select FunctionKey and KeyPad on Putty. Configuration options: [VT100] [LINUX] [XTERMR6] [SCO] [ESCN] [VT400]

3.3.10 SATA Configuration

This item allows you to configure SATA device options settings.

SATA Controller(s)

Allows you to enable or disable the onboard SATA device. Configuration options: [Disabled] [Enabled]



The following item appears only when you set **SATA Controller(s)** to **[Enabled]**.

SATA Mode Selection

Allows you to determine how SATA controller(s) operate. Configuration options: [AHCI]

[AHCI] Set to [AHCI] when you want the SATA hard disk drives to use the AHCI (Advanced Host Controller Interface). The AHCI allows the onboard storage driver to enable advanced Serial ATA features that increases storage performance on random workloads by allowing the drive to internally optimize the order of commands.

SATA6G_1/2/3/4

Allow you to enable/disable the SATA6G_1/2/3/4 port. Configuration options: [Disabled] [Enabled]

3.3.11 Network Stack Configuration

Network Stack

This item allows user to disable or enable the UEFI network stack. Configuration options: [Disabled] [Enabled]



The following two items appear only when you set the previous item to [Enabled].

Ipv4 PXE Support

This item allows user to disable or enable the Ipv4 PXE Boot support. Configuration options: [Disabled] [Enabled]

Ipv6 PXE Support

This item allows user to disable or enable the Ipv6 PXE Boot support. Configuration options: [Disabled] [Enabled]

3.3.12 USB Configuration

XHCI Hand-off

This item functions as a workaround for Oses without XHCI hand-off support. The XHCI ownership change should be claimed by XHCI driver. Configuration options: [Enabled] [Disabled]

USB Mass Storage Driver Support

Allows you to enable or disable USB Mass Storage Driver Support. Configuration options: [Disabled] [Enabled]

LAN1_U32G1_1~2, LAN2_U32G1_3~4, USB_5~8

Allows you to enable or disable USB port. Once set to **[Disabled]**, any USB devices plugged into the connector will not be detected by BIOS or OS. Configuration options: [Disabled] [Enabled]

3.3.13 NVMe Configuration

The NVMe Configuration menu displays the NVMe controller and drive information of the devices connected and allows you to configure NVMe device options settings.

3.3.14 Onboard Devices Configuration

HD Audio

[Enabled] Enables the HD Audio Device.

[Disabled] Disables the HD Audio Device.

LAN1 I219

[Enabled] Enables the Intel LAN1 controller.

[Disabled] Disables the controller.

LAN2 I210

[Enabled] Enables the Intel LAN2 controller.

[Disabled] Disables the controller.

M.2 WiFi

Allow you to enable or disable M.2 WiFi function. Configuration options: [Enabled]
[Disabled]

M.2 BT

Allow you to enable or disable M.2 BT function. Configuration options: [Enabled]
[Disabled]

3.3.15 APM Configuration

ErP Ready

Allows you to switch off some power at S5 to get the system ready for ErP requirement. When set to **[Enabled]**, all other PME options will be switched off. Configuration options: [Disabled] [Enabled]

Restore AC Power Loss

[S5 State] The system goes into off state after an AC power loss.

[S0 State] The system goes into on state after an AC power loss.

Power On By PCIE

This item allows you to enable or disable the Wake-on-LAN function of the onboard LAN controller or other installed PCIe/PCI LAN cards. Configuration options: [Disabled] [Enabled]

Power On By Ring

[Enabled] Enables the Ring devices to generate a wake event.

[Disabled] Disables the Ring devices to generate a wake event.

Power On By RTC

[Disabled] Disables RTC to generate a wake event.

[Single event] Allows you to generate a single wake event.

[Daily event] Allows you to generate a daily wake event.

[Weekly event] Allows you to generate a weekly wake event.

[Monthly event] Allows you to generate a monthly wake event.

3.3.16 EZ-Flash

Enter Ez-Flash mode

This item allows you to run EzFlash utility. When you press <Enter>, a confirmation message appears. Use the left/right arrow key to select between [Yes] or [No], then press <Enter> to confirm your choice.

3.3.17 IO Expander Configuration

IO Expander GPIO 0(~7)

Direction

Allows you to select the direction of this GPIO.
Configuration options: [Output] [Input]

Output Value

Allows you to select the output value of this GPIO.
Configuration options: [Low] [High]

3.3.18 Watchdog Timer

Watchdog Support

This item allows you to enable or disable Watchdog timer. Configuration options: [Enabled] [Disabled]



The following items appear when you set **Watchdog Support** to [Enabled].

Watchdog Count mode

Allows you to select Watchdog Timer I count mode.
Configuration options: [Second Mode] [Minute Mode]

Watchdog Timer

Use the <+> and <-> keys to adjust the value or input the desired value directly.
The value ranges from 1 to 255.

3.4 Hardware Monitor menu

The items in this menu provide you an overview of system status including temperature, fan speed and voltage, and allow you to configure the smart fan.

Smart Fan Mode

Allows you to select the smart fan mode. Configuration options: [Disabled] [Normal] [Manual Mode]



The following item appears only when you set **Smart Fan Mode** to [Manual Mode].

Smart Fan Function

System Fan Setting

Chassis Fan Temperature 1(~4)

Allows you to set the value of temperature1(~4).

Chassis Fan FD/RPM 1(~4)

Allows you to set the value of Fan Duty/PRM 1(~4) when temperature is T1(~4).

CPU Fan Setting

CPU Fan Temperature 1(~4)

Allows you to set the value of temperature1(~4).

CPU Fan FD/RPM 1(~4)

Allows you to set the value of Fan Duty/PRM 1(~4) when temperature is T1(~4).

3.5 Security menu

This menu allows a new password to be created or a current password to be changed. The menu also enables or disables the Secure Boot state and lets the user configure the System Mode state.

Administrator Password

If you have set an administrator password, we recommend that you enter the administrator password for accessing the system.

To set an administrator password:

1. Select the **Administrator Password** item and press <Enter>.
2. From the **Create New Password** box, key in a password, then press <Enter>.
3. Confirm the password when prompted.

To change an administrator password:

1. Select the **Administrator Password** item and press <Enter>.
2. From the **Enter Current Password** box, key in the current password, then press <Enter>.
3. From the **Create New Password box**, key in a new password, then press <Enter>.
4. Confirm the password when prompted.



To clear the administrator password, follow the same steps as in changing an administrator password, but press <Enter> when prompted to create/confirm the password.

User Password

If you have set a user password, you must enter the user password for accessing the system. The **User Password** item on top of the screen shows the default **Not Installed**. After you set a password, this item shows **Installed**.

To set a user password:

1. Select the **User Password** item and press <Enter>.
2. From the **Create New Password** box, key in a password, then press <Enter>.
3. Confirm the password when prompted.

To change a user password:

1. Select the **User Password** item and press <Enter>.
2. From the **Enter Current Password** box, key in the current password, then press <Enter>.
3. From the **Create New Password** box, key in a new password, then press <Enter>.
4. Confirm the password when prompted.

Secure Boot**Secure Boot**

Secure Boot can be enabled if the system is running in User mode with enrolled platform Key (EPK) or if the CSM function is disabled. Configuration options: [Disabled] [Enabled]

Secure Boot Mode

In Custom mode, Secure Boot policy variables can be configured by a physically present user without full authentication. Configuration options: [Standard] [Custom]

Key Management

The Key Management item allows you to modify Secure Boot variables and set Key Management page.

Platform Key (PK) / Key Exchange Keys / Authorized Signatures / Forbidden Signatures
Configuration options: [Update] [Append]

3.6 Boot menu

The Boot menu items allow you to change the system boot options.

Boot Configuration**CHASSIS INTRUDE**

Allows you to enable or disable the chassis intrusion detection function. Configuration options: [Disabled] [Enabled]

Setup Prompt Timeout

Allows you to set the number of seconds to wait for setup activation key. 65535(0xFFFF) means indefinite waiting. Configuration options: [1] - [65535]

Post Time Delay

This item allows you to select the desired additional POST waiting time to easily enter the BIOS setup. (Delay time = value * 500ms). Configuration options: [0] - [12]

Boot up NumLock State

[On] Set the power-on state of the NumLock to [On].

[Off] Set the power-on state of the NumLock to [Off].

Quiet Boot

Allows you to enable or disable the Quiet Boot option.

Configuration options: [Disabled] [Enabled]

Fast Boot

[Enabled] Select to accelerate the boot speed.

[Disable Link] Select to go back to normal boot.

FIXED BOOT ORDER Priorities

Boot Option #1~#6

This item allows you to set the system boot order. Configuration options: [Hard Disk] [NVME] [CD/DVD] [SD] [USB Device] [Network] [Disabled]

3.7 Exit menu

The Exit menu items allow you to save or discard your changes to the BIOS items.

Save Changes and Exit

This option allows you to save your changes and exit the Setup program. When you select this option or if you press <Esc>, a confirmation window appears. Select **Yes** to save changes and exit.

Discard Changes and Exit

This option allows you to exit the Setup program without saving your changes. When you select this option or if you press <Esc>, a confirmation window appears. Select **Yes** to discard changes and exit.

Save Changes and Reset

This option allows you to exit the Setup program after saving changes.

Discard Changes and Reset

This option allows you to exit the Setup program without saving changes.

Save changes

This option allows you to save changes to any of the setup options you have made so far.

Discard changes

This option allows you to discard changes to any of the setup options you have made so far.

Restore Defaults

Restore/load default values for all the setup options.

Save as User Defaults

This option allows you to save the changes you have made so far as user defaults.

Restore User Defaults

Restore the user defaults with all the setup options.

Appendix

Notices

FCC Compliance Information

Responsible Party: Asus Computer International

Address: 48720 Kato Rd., Fremont, CA 94538, USA

Phone / Fax No: (510)739-3777 / (510)608-4555

This device complies with part 15 of the FCC Rules. Operation is subject to the following two conditions: (1) This device may not cause harmful interference, and (2) this device must accept any interference received, including interference that may cause undesired operation.

This equipment has been tested and found to comply with the limits for a Class B digital device, pursuant to part 15 of the FCC Rules. These limits are designed to provide reasonable protection against harmful interference in a residential installation. This equipment generates, uses and can radiate radio frequency energy and, if not installed and used in accordance with the instructions, may cause harmful interference to radio communications. However, there is no guarantee that interference will not occur in a particular installation. If this equipment does cause harmful interference to radio or television reception, which can be determined by turning the equipment off and on, the user is encouraged to try to correct the interference by one or more of the following measures:

- Reorient or relocate the receiving antenna.
- Increase the separation between the equipment and receiver.
- Connect the equipment into an outlet on a circuit different from that to which the receiver is connected.
- Consult the dealer or an experienced radio/TV technician for help.

Compliance Statement of Innovation, Science and Economic Development Canada (ISED)

This device complies with Innovation, Science and Economic Development Canada licence exempt RSS standard(s). Operation is subject to the following two conditions: (1) this device may not cause interference, and (2) this device must accept any interference, including interference that may cause undesired operation of the device.

CAN ICES-003(B)/NMB-003(B)

Déclaration de conformité de Innovation, Sciences et Développement économique Canada (ISED)

Le présent appareil est conforme aux CNR d'Innovation, Sciences et Développement économique Canada applicables aux appareils radio exempts de licence. L'exploitation est autorisée aux deux conditions suivantes : (1) l'appareil ne doit pas produire de brouillage, et (2) l'utilisateur de l'appareil doit accepter tout brouillage radioélectrique subi, même si le brouillage est susceptible d'en compromettre le fonctionnement.

CAN ICES-003(B)/NMB-003(B)

VCCI: Japan Compliance Statement

Class B ITE

この装置は、クラスB情報技術装置です。この装置は、家庭環境で使用することを目的としていますが、この装置がラジオやテレビジョン受信機に近接して使用されると、受信障害を引き起こすことがあります。

取扱説明書に従って正しい取り扱いをして下さい。

VCCI-B

KC: Korea Warning Statement

B급 기기 (가정용 방송통신기자재)

이 기기는 가정용(B급) 전자파적합기기로서 주로 가정에서 사용하는 것을 목적으로 하며, 모든 지역에서 사용할 수 있습니다.

HDMI Trademark Notice

The terms HDMI, HDMI High-Definition Multimedia Interface, HDMI Trade dress, and the HDMI Logo are trademarks or registered trademarks of HDMI Licensing Administrator, Inc.

HDMI™
HIGH-DEFINITION MULTIMEDIA INTERFACE

REACH

Complying with the REACH (Registration, Evaluation, Authorisation, and Restriction of Chemicals) regulatory framework, we published the chemical substances in our products at ASUS REACH website at <http://csr.asus.com/english/REACH.htm>.



DO NOT throw the motherboard in municipal waste. This product has been designed to enable proper reuse of parts and recycling. This symbol of the crossed out wheeled bin indicates that the product (electrical and electronic equipment) should not be placed in municipal waste. Check local regulations for disposal of electronic products.



DO NOT throw the mercury-containing button cell battery in municipal waste. This symbol of the crossed out wheeled bin indicates that the battery should not be placed in municipal waste.

ASUS Recycling/Takeback Services

ASUS recycling and takeback programs come from our commitment to the highest standards for protecting our environment. We believe in providing solutions for you to be able to responsibly recycle our products, batteries, other components as well as the packaging materials. Please go to <http://csr.asus.com/english/Takeback.htm> for detailed recycling information in different regions.

English ASUSTek Computer Inc. hereby declares that this device is in compliance with the essential requirements and other relevant provisions of related Directives. Full text of EU declaration of conformity is available at: www.asus.com/support

Français AsusTek Computer Inc. déclare par la présente que cet appareil est conforme aux critères essentiels et autres clauses pertinentes des directives concernées. La déclaration de conformité de l'UE peut être téléchargée à partir du site Internet suivant: www.asus.com/support

Deutsch ASUSTek Computer Inc. erklärt hiermit, dass dieses Gerät mit den wesentlichen Anforderungen und anderen relevanten Bestimmungen der zugehörigen Richtlinien übereinstimmt. Der gesamte Text der EU-Konformitätserklärung ist verfügbar unter: www.asus.com/support

Italiano ASUSTek Computer Inc. con la presente dichiara che questo dispositivo è conforme ai requisiti essenziali e alle altre disposizioni pertinenti con le direttive correlate. Il testo completo della dichiarazione di conformità UE è disponibile all'indirizzo: www.asus.com/support

Русский Компания ASUS заявляет, что это устройство соответствует основным требованиям и другим соответствующим условиям соответствующих директив. Подробную информацию, пожалуйста, смотрите на www.asus.com/support

Български С настоящото ASUSTEK Computer Inc. декларира, че това устройство е в съответствие със съществените изисквания и другите приложими постановления на свързаните директиви. Пълният текст на декларацията за съответствие на ЕС е достъпен на адрес: www.asus.com/support

Hrvatski ASUSTEK Computer Inc. ovim izjavljuje da je ovaj uređaj skladan s bitnim zahtjevima i ostalim odgovarajućim odredbama vezanih direktiva. Cijeli tekst EU izjave o skladnosti dostupan je na: www.asus.com/support

Čeština Společnost ASUSTEK Computer Inc. tímto prohlašuje, že toto zařízení splňuje základní požadavky a další příslušná ustanovení souvisejících směrnic. Plné znění prohlášení o shodě EU je k dispozici na adrese: www.asus.com/support

Dansk ASUSTEK Computer Inc. erklærer hermed, at denne enhed er i overensstemmelse med hovedkravene og andre relevante bestemmelser i de relaterede direktiver. Hele EU-overensstemmelseserklæringen kan findes på: www.asus.com/support

Nederlands ASUSTEK Computer Inc. verklaart hierbij dat dit apparaat voldoet aan de essentiële vereisten en andere relevante bepalingen van de verwante richtlijnen. De volledige tekst van de EU-verklaring van conformiteit is beschikbaar op: www.asus.com/support

Eesti Käesolevaga kinnitab ASUSTEK Computer Inc, et see seade vastab asjakohaste direktiivide olulistele nõuetele ja teistele asjassepuutuvatele sätetele. El vastavusdeklaratsiooni täielik tekst on saadaval järgmisel aadressil: www.asus.com/support

Suomi ASUSTEK Computer Inc. ilmoittaa täten, että tämä laite on asiaankuuluvien direktiivien olennaisten vaatimusten ja muiden tätä koskevien säädösten mukainen. EU-yhdenmukaisuusilmoituksen koko teksti on luettavissa osoitteessa: www.asus.com/support

Ελληνικά Με το παρόν, η ASUStek Computer Inc. δηλώνει ότι αυτή η συσκευή συμμορφώνεται με τις θεμελιώδεις απαιτήσεις και άλλες σχετικές διατάξεις των Οδηγιών της ΕΕ. Το πλήρες κείμενο της δήλωσης συμμόρφωσης είναι διαθέσιμο στη διεύθυνση: www.asus.com/support

Magyar Az ASUSTEK Computer Inc. ezennel kijelenti, hogy ez az eszköz megfelel a kapcsolódó irányelvek lényeges követelményeinek és egyéb vonatkozó rendelkezéseinek. Az EU megfélelősegi nyilatkozat teljes szövege innen letölthető: www.asus.com/support

Latviski ASUSTEK Computer Inc. ar šo paziņo, ka šī ierīce atbilst saistošo Direktīvu būtiskajām prasībām un citiem citiem saistošajiem nosacījumiem. Pilns ES atbilstības paziņojuma teksts pieejams šeit: www.asus.com/support

Lietuvių „ASUSTEK Computer Inc.“ šiuo tvirtina, kad šis įrenginys atitinka pagrindinius reikalavimus ir kitas svarbias susijusių direktyvų nuostatas. Visą ES atitikties deklaracijos tekstą galima rasti: www.asus.com/support

Norsk ASUSTEK Computer Inc. erklærer herved at denne enheten er i samsvar med hovedsaklige krav og andre relevante forskrifter i relaterte direktiver. Fullstendig tekst for EU-samsvarserklæringen finnes på: www.asus.com/support

Polski Firma ASUSTEK Computer Inc. niniejszym oświadcza, że urządzenie to jest zgodne z zasadniczymi wymogami i innymi właściwymi postanowieniami powiązanych dyrektyw. Pełny tekst deklaracji zgodności UE jest dostępny pod adresem: www.asus.com/support

Português A ASUSTEK Computer Inc. declara que este dispositivo está em conformidade com os requisitos essenciais e outras disposições relevantes das Diretivas relacionadas. Texto integral da declaração da UE disponível em: www.asus.com/support

Română ASUSTEK Computer Inc. declară că acest dispozitiv se conformează cerințelor esențiale și altor prevederi relevante ale directivelor conexe. Textul complet al declarației de conformitate a Uniunii Europene se găsește la: www.asus.com/support

Srpski ASUSTEK Computer Inc. ovim izjavljuje da je ovaj uređaj u saglasnosti sa osnovnim zahtevima i drugim relevantnijim odredbama povezanih Direktiva. Pun tekst EU deklaracije o usaglasenosti je dostupan da adres: www.asus.com/support

Slovensky Spoločnosť ASUSTEK Computer Inc. týmto vyhlasuje, že toto zariadenie vyhovuje základným požiadavkám a ostatým príslušným ustanoveniam príslušných smerníc. Celý text vyhlásenia o zhode pre štáty EÚ je dostupný na adrese: www.asus.com/support

Slovenščina ASUSTEK Computer Inc. izjavlja, da je ta naprava skladna z bistvenimi zahtevami in drugimi ustreznimi določbami povezanih direktiv. Celotno besedilo EU-izjave o skladnosti je na voljo na spletnem mestu: www.asus.com/support

Español Por la presente, ASUSTEK Computer Inc. declara que este dispositivo cumple los requisitos básicos y otras disposiciones pertinentes de las directivas relacionadas. El texto completo de la declaración de la UE de conformidad está disponible en: www.asus.com/support

Svenska ASUSTEK Computer Inc. förklarar härmed att denna enhet överensstämmer med de grundläggande kraven och andra relevanta föreskrifter i relaterade direktiv. Fulltext av EU-försäkran om överensstämmelse finns på: www.asus.com/support

Українська ASUSTEK Computer Inc. заявляє, що цей пристрій відповідає основним вимогам та іншим відповідним положенням відповідних Директив. Повний текст декларації відповідності стандартам ЄС доступний на: www.asus.com/support

Türkçe ASUSTEK Computer Inc., bu aygıtın temel gereksinimlerle ve ilişkili Yönergelerin diğer ilgili koşullarına uyumlu olduğunu beyan eder. AB uygunluk bildirimini tam metni şu adreste bulunabilir: www.asus.com/support

Bosanski ASUSTEK Computer Inc. ovim izjavljuje da je ovaj uređaj uskladen sa bitnim zahtjevima i ostalim odgovarajućim odredbama vezanih direktiva. Cijeli tekst EU izjave o uskladenosti dostupan je na: www.asus.com/support

Service and Support

Visit our multi-language website at <https://www.asus.com/support/>

